

# THERMOWHEEL®

## TR Series Retrofit Wheel Systems

**RE-INVENTING THE WHEEL**

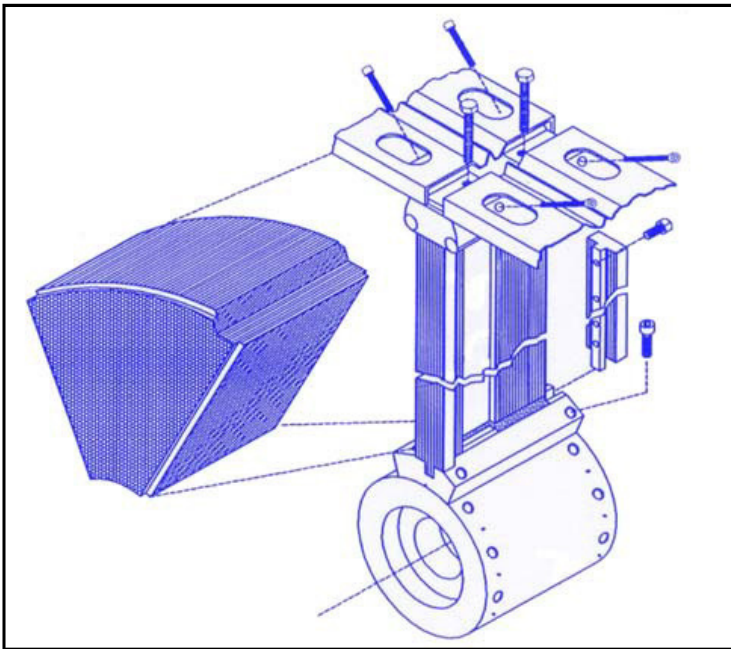
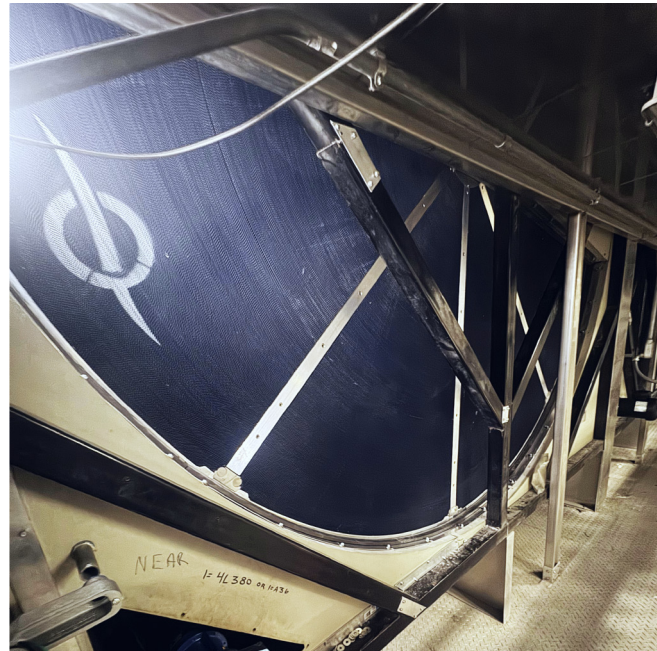
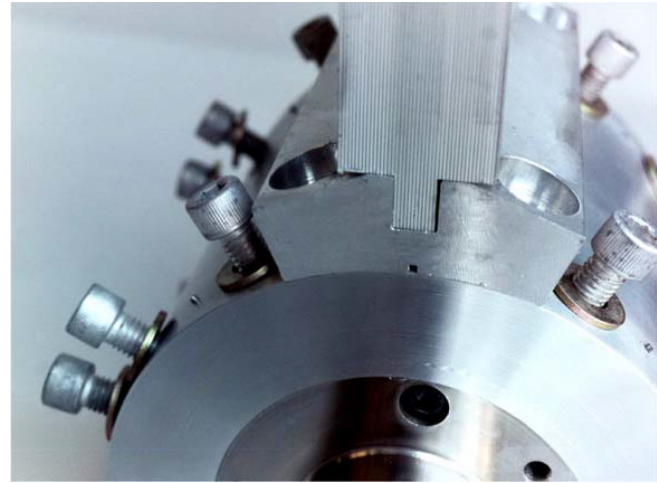

Engineering Reliability  
and Performance

Built For The Real World

Installed In The Real World

The TR Series THERMOWHEEL® is the most reliable energy recovery wheel retrofit product available. We back every product with a standard 10 year warranty. After performing hundreds of field installations of other manufacturers' wheels, the engineers at Thermotech have redesigned each of the major components to solve many of the problems encountered in the field.

## Features:

### **25 Year Minimum Design life**

- Eliminates Wheel Failures
- Low Maintenance
- High Performance
- Low Cost Per Life Cycle
- Flexibility in Installation
- Multiple Media Options

**Retrofits can be turnkey or we can supervise your contractor or staff.**

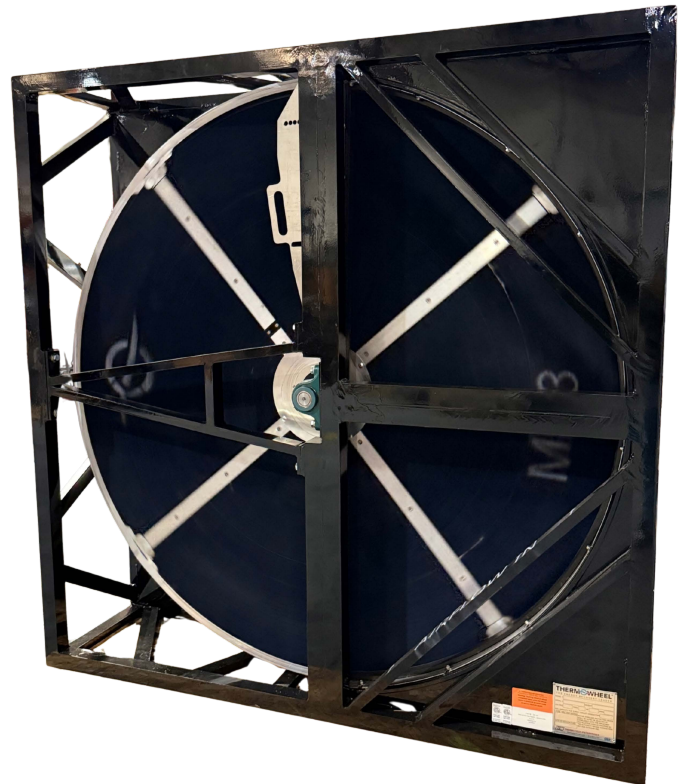

**The TR SERIES THERMOWHEEL®** is designed from the ground up to be installed in the field as a replacement for existing heat recovery wheel products. The TR SERIES is a direct replacement for Berner, Cargocaire, SEMCO, Regenerative Heat Corp., Enreco, Governair, Flakt, Wing, Carnes, Heat Recovery Corp., Munters, DesChamps, NovelAire DRI, Innergy Tech and others.

This brochure will guide you through the features that give the TR Series its legendary reliability and performance and provide a cross-reference to many of the common retrofit wheel sizes. If your existing wheel is not listed on the chart in this brochure contact Thermotech or your local representative. We will provide a retrofit form for your type of wheel. Based on the information provided we can specify the correct TR Series model number and provide an energy savings analysis. With the energy analysis you will be able to get reliable numbers on your payback for upgrading to a TR Series Thermowheel® . Contact Thermotech and start saving today!

All Thermowheel products are manufactured in the USA at a state of the art facility located in Tampa FL. Factory tours are available. Contact TE or your representative for more information.



## The Rotor Assembly:

Rotors consist of 3 main parts: hub and bearing assembly, spokes and rim. Each segment consists of media supported by spokes and tensioned in place by the rim.

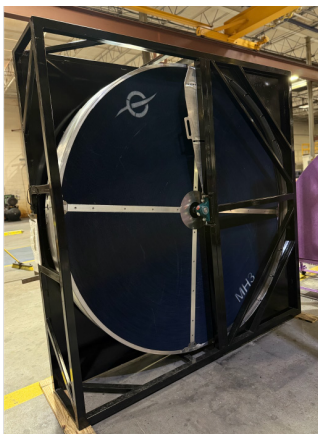

## Rim Connector:



TR Series wheels feature a patented rim and spoke design which allows for each section of the wheel to be tensioned independently. This simplifies field assembly and provides a flatter, rounder and stronger wheel.

## Spokes: Spokes provide the structural integrity to limit deflection of the wheel and to eliminate mechanical fatigue of the media.

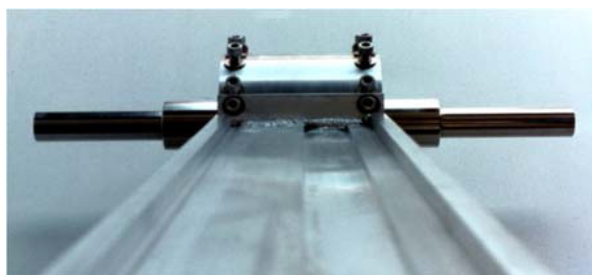

TR Series spokes are extruded aluminum fashioned in the form of an "I" beam for added strength. Each spoke has grooves which correspond to matching grooves machined into the media.

This assures that each section of media is held securely in the exact position needed for a flat wheel.

## Rims: The rim holds each section of media in place and provides an area for the belts to ride.

The rims are made from extruded aluminum and have "V" shaped grooves for the drive belts. This keeps the belts securely seated. The rims have ridges on the inside perimeter that fit into grooves machined in the media. This holds the media in proper position and provides a round and flat wheel.

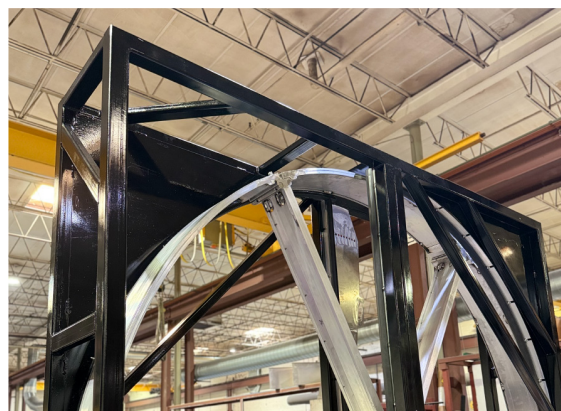

## The Hub and Bearing Assembly:

The hub and bearing assembly support the wheel in the casing.

Hub and bearings are the foundation on which the wheel is built. We use tapered roller bearings and machine each hub and shaft to the bearing manufacturer's tolerance. This provides the reliability needed for a minimum L-10 life of 1,000,000 hours.

### The Seals:

Seals must be strong, flexible and secure once in place. To achieve this, the seal is installed with an extruded aluminum strip mated to a labyrinth design extruded rubber seal that is secured directly to the wheel frame.

The seals can be set to 1/32" clearance from the media face, because our "I" beam spokes feature almost zero deflection. This reduces leakage around the seals and provides for maximum performance and reliability.



### The Motor Drive System:

The drive design is crucial to long term operation. A simple gravity tensioned twin "V" belt provides for outstanding performance and reliability. The belts ride in a groove on the rim to eliminate slippage and side to side belt movement. The drive is designed for a minimum life of 90,000 hours. A direct drive option is available with the speed reducer connected to an extended shaft via a keyway. All our motors feature variable or constant speed drive depending on the application. We use standard "V" belts, available at most supply stores, since this is the only part of a Thermowheel® that should ever need replacing.



### Control System:

**The control system and sensors measure the temperature and/or humidity of the different air streams and control the wheel speed for maximum efficiency.**

Our control system can be configured to provide the proper operation of the energy recovery wheel in all conditions and environments. We can custom configure the sensors so that the customer obtains the data and control required to ensure the highest operational efficiency. We can provide the interface to any existing HVAC control system.

The ETL Listed, UL 508A Approved Control Panel is Enclosed in A NEMA 4 Cabinet.



### Media: The media provides for the transfer of heat and moisture between the airstreams.

Balanced Sieve 3Å desiccant-coated molecular sieve media, is the most efficient enthalpy media available. It features a micro engineered desiccant coating and is performance tested in accordance with ASHRAE Standard 84-91 and ARI Standard 1060-01. Epoxy coated sensible media, dehumidification media, and media for high temperature and corrosive environments is also available.

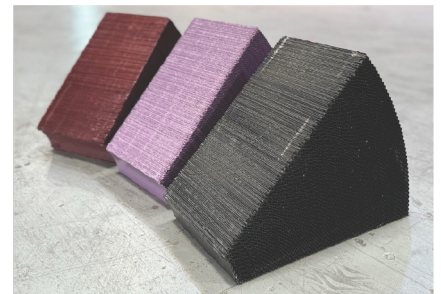

Thermotech has performed retrofits at hospitals, labs, manufacturing and processing plants, schools and universities. Contact Thermotech and learn why so many major companies choose the TR Series Thermowheel.®





## TR Series Partial Replacement Manufacturers List

Thermotech has a vast database of other manufacturers' heat wheels. From these charts you can find the TR Series replacement for your existing unit. Some units may require an on site measurement to determine certain specific details.

Thermowheel™	Berner/ Senex	Cargocaire	Carnes	DRI	Enreco	Governair	Heat Recovery Corp	Munters/ Flakt	Regen Heat Corp	Seibu Giken (SGA)	SEMCO	Wing
TR-723				HRW-167		HWL-T-168				4200		
TR-697	SE-660	EC-60000						420			TE3-70	WE-6250
TR-620						HWL-T-156				3900		
TR-572								380			TE3-60	
TR-556				HRW-149							TE3-56	
TR-526			144		EW-54	HWL-T-144	50					
TR-503										3500		
TR-474	SA-490E	EC-40000						350			TE3-50	WE-4770
TR-460	SE-490			HRW-136							TE3-46	
TR-432			132		EW-45	HWL-T-132	40		80			
TR-418	SE-410			HRW-131							TE3-43	
TR-398												WE-4000
TR-385							35	320	70	3100	TE3-41	
TR-359			120		EW-37	HWL-T-120						
TR-347				HRW-120						2900	TE3-35	
TR-329	SA-330E	EC-30000						290	60			WE-3160
TR-311	SE-330		110		EW-31		27 1/2				TE3-33	
TR-294				HRW-111		HWL-T-108						
TR-282				HRW-108			25	265	50	2600	TE3-28	
TR-261											27VL	
TR-245			99	HRW-101	EW-25		22 1/2			2400		
TR-225	SA-220E	EC-20000				HWL-T-96		240				WE-2150
TR-215	SE-220			HRW-96			20		40		TE3-24	
TR-191		EC-16000	88	HRW-91	EW-20	HWL-T-88	17 1/2	215			TE3-20	
TR-182				HRW-88						2150		
TR-173	SE-180; SA-180E										TE3-18	
TR-165							15					
TR-152				HRW-81		HWL-T-78			28			
TR-144	SA-140E	EC-12000		HRW-78				190		1900	TE3-15	WE-1400
TR-136	SE-140		74	HRW-75	EW-14		12 1/2					
TR-121						HWL-T-70					TE3-13	
TR-114	SE-110			HRW-70			10	170	20	1700	10VL	
TR-96				HRW-65		HWL-T-62	9			1500	TE3-10	
TR-87	SA-90E		60	HRW-62	EW-9		8	150				
TR-81	SE-90	EC-7500									TE3-9	WE-875

If you don't find your wheel listed, contact TE and we will provide a retrofit form for your wheel.

**Installation:** The patented design of the THERMOWHEEL® simplifies field installation and provides a flatter, stronger, more reliable wheel.



The installation of TR Series wheels can be performed by our trained technicians or by your contractor or staff with our supervision. The casing, when required, is constructed of tubular steel or aluminum and is of a modular design built in either 2 or more sections to provide for easy assembly.



Most wheels don't fail because the media isn't doing its job. They fail because of structural design faults.

### Problems solved by Thermowheel®



Common failures like these pictured here are caused by flawed designs. The T Series THERMOWHEEL® solves all of these problems and more.



Engineering  
Reliability  
And  
Performance



**Casing Frame Structure:**

The structural frame of the existing casing shall remain intact to avoid any disconnection of the duct transitions and resulting interruption of the operation. The frame structure shall be upgraded as necessary to achieve an acceptable rotor deflection of maximum 1/32 inch, as measured at the outer radius, during maximum rated airflow condition, and thereby eliminating excessive air seal bypass and/or additional seal drag. All structural improvements, including all welds, shall be painted with red oxide primer.

**Sheet Metal:**

All existing sheet metal shall be reinforced as required to provide a solid mounting surface of the new peripheral and radial seals in order to maintain a minimum of 3/8 inch fixed distance between the rotor surface and any sheet metal or steel parts. A minimum of two halves, air entry areas, of the rotor surface shall be sealed off to force the air through the heat transfer media minimizing cross leakage and bypass.

**Purge Section:**

The existing purge section may be reused if it can be determined that it is structurally sound and that it is functioning correctly for the existing design conditions. If a change is required for proper operation it may be replaced, modified or combined with an added purge adjuster or limiter in order to achieve a satisfactory purge flow.

**Hub and Bearings:**

New bearings may be of the same rating as the old providing they were properly sized to provide a minimum L-10 life of 1,000,000 hours of operation. If this condition can't be met, appropriate modification shall be made to accommodate a bearing that can, or a hub with internal tapered roller bearings sized for an L-10 life of 438,000 hours may be used as a substitute. Regardless of the type of bearings selected, internal or external, provisions shall be made for grease fittings that are easily accessible. External bearing shaft journals shall be machined to proper tolerance as specified by the bearing manufacturer to avoid any problems with bearing setscrews loosening and premature shaft wear. The new hub/shaft shall be installable and removable without any cutting or removal of any structural steel members essential for maintaining structural integrity of the casing.

**Spokes:**

The spokes shall be made of extruded aluminum with an I-beam shape to limit deflection of the rotor to 1/32 inch for the maximum rated airflow. Spoke surfaces to be serrated for increased friction and air turbulence across the seals.

**Rims:**

The rims shall be made of two extruded aluminum sections -- one inner rim and one outer rim with grooves for the twin V-belts, and guide flanges for securing the media. The two sections shall be welded together to form a tubular structure for improved strength in order to maintain an accurate radius and rotor roundness during the manufacturing process.

**Rim Joint:**

The rim joint shall connect the spoke ends and the rim ends together in such a way that the heat transfer media can be installed under field conditions without any media deformation or misfits causing future problems. The rim joints shall provide a gradual compression of each section by independently applying increased tension of the rim bolts without the use of any special tools or devices.

**Rotor Media:**

The rotor media must be provided in segments. Each media segment must be machined to fit in between a primary and secondary spoke and a guiding flange of the outside rim. Each segment of media must be compressed independently of all other segments during the assembly process without causing any angular deformation and resulting misfits between the spokes and media parts, and to provide a wheel with a flatness of +/- 1/32". No adhesives or silicone shall be necessary to secure the media in place in order to allow for future replacement in the event of damage to a section. The rotor system must be able to accommodate all acceptable media types for applications requiring equal sensible and latent recovery.

**Media Continued:**

The heat transfer media shall be the industry standard of 200 mm. in depth. Non-standard depths shall be unacceptable. The heat transfer media shall be made out of corrugated aluminum foil with a high surface area per volume and laminar flow to assure that no fouling occurs on the internal heat transfer surface. Dry particles up to 900 microns shall pass freely through the media. This material shall be supplied with a "Balanced Sieve" (3Å Molecular Sieve) hygroscopic solid desiccant coating for selective adsorption of water vapor and equal sensible and latent heat transfer. The media shall have a flame spread of 0 and a smoke developed of 5 or less when rated in accordance with ASTM E84-09. All edges shall have an anti-corrosion epoxy coating. Rotor media shall be tested in accordance with ASHRAE Standard 84-91 and ARI Standard 1060-01 by a qualified independent testing laboratory. Testing shall confirm published performance and document that the desiccant material does not transfer pollutants typically encountered in the indoor air environment. The reports shall be provided upon request.

**Seals:**

The seals shall be of a maintenance free non-contact type with a 4-pass labyrinth "turbine" for optimum performance and designed to eliminate wear and excessive drag. The seals shall be adjustable and set to within 0.05 inch of the rotor surface and shall be bolted to the frame, with stainless steel hardware, to eliminate seal movement. The seal system shall be able to withstand a pressure difference up to 12 in. W.C.

**Drive System:**

The drive must be gravity tensioned and shall use 2 standard "B" section V- belts to drive the rotor. The speed reducer must be grease lubricated, maintenance free with a flexible Love-Joy input coupling or a Direct Drive Motor and Speed reducer shall be attached to the extended shaft via a key-way.

**Speed Control:**

The speed control system shall be a variable frequency inverter operating a standard inverter rated AC motor, capable of operating the rotor from 1/4 rpm to 20 rpm or to whatever is required for the type of media used. It shall integrate with the control system.

**Controller:**

The controller shall monitor entering and leaving temperatures for the exhaust and supply air. Adjustable set points shall be for the sleep mode, cool/heat -- supply air temperature -- and the wheel frost control.

**Maintenance:**

The entire rotor and wheel assembly shall require only limited maintenance of biannual greasing of the main bearings and inspection of the drive system, bearings and inspection of the drive system.

**Warranty:**

A standard 10 or 3 year material and labor warranty covering all materials supplied and installed by Thermotech.

info@thermotech-usa.com

Tel (813) 865-4701

[www.thermotech-usa.com](http://www.thermotech-usa.com)