

THERMOWHEEL®

T Series Energy Recovery Wheel Systems

- 10 Year Parts and Labor Warranty - TF & TR
- 1,000,000 Hour L10 Life Bearings
- 25 Year Minimum Design Life
- Direct or Belt Drive

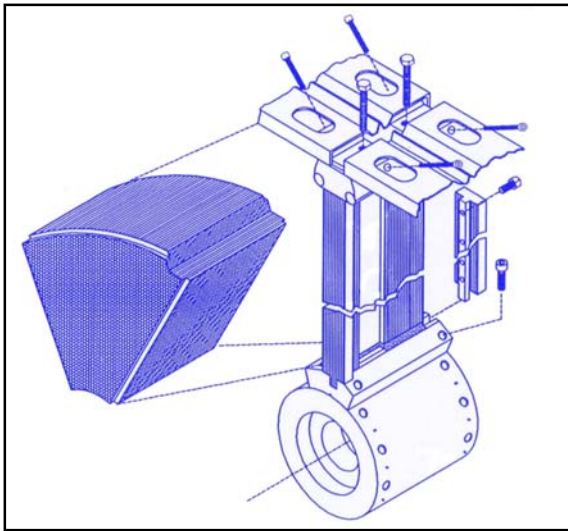

Engineering Reliability
and Performance
Re-Inventing The Wheel

info@thermotech-usa.com
Tel (813) 865-4701
www.thermotech-usa.com

The THERMOWHEEL® is the most reliable energy recovery wheel available. We back every product with a standard 3 or 10 year warranty. After performing hundreds of field installations of other manufacturers' wheels, the engineers at Thermotech have redesigned each of the major components to solve many of the problems encountered in the field.

Features:

25 Year Minimum Design Life

- Eliminates Wheel Failures
- Low Maintenance
- High Performance
- Low Cost Per Life Cycle
- Flexibility in Installation
- Multiple Media Options

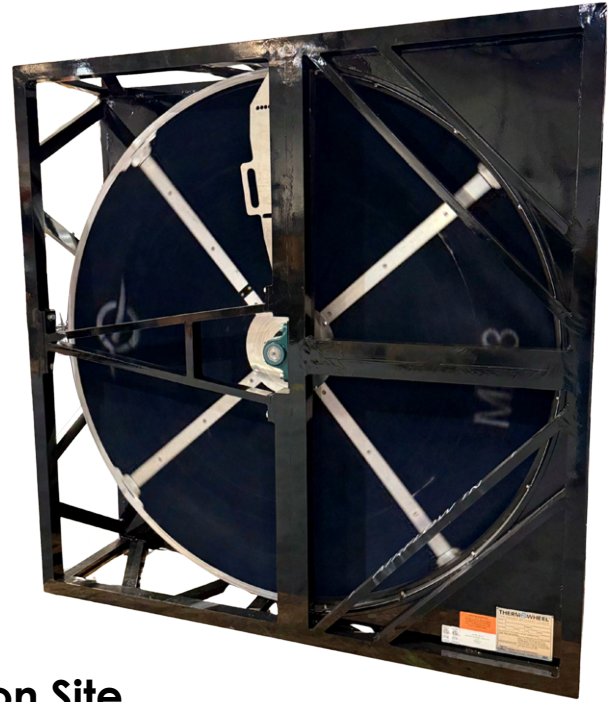

Shipped Fully Assembled or Assemble on Site

The **TR SERIES THERMOWHEEL®** is designed from the ground up to be installed in the field as a replacement for existing heat recovery wheel products. The TR SERIES is a direct replacement for Berner, Cargocaire, SEMCO, Regenerative Heat Corp., Enreco, Governair, Flakt, Wing, Carnes, Heat Recovery Corp., Munters and others.

The **TF SERIES THERMOWHEEL®** is designed for new air handler applications in the 12,000 to 150,000 CFM range. One of the advantages of our unique design is that the unit can be shipped fully assembled or assembled in the field. If your facility requires a new heat recovery wheel or when limited access demands a field assembly of the wheel, the TF SERIES is the answer. The TF is available in sizes up to 21' in diameter.

The **TC SERIES THERMOWHEEL®** is designed for new air handler applications in the 500 to 20,000 CFM range and is shipped fully assembled in an aluminum frame. The TC is an economical alternative to the TF series wheel.

Because of our patented **THERMOWHEEL®** rotor design, the wheel is very strong and flat. The **THERMOWHEEL®** rotor design features almost zero spoke deflection.

The Rotor Assembly:

Rotors consist of 3 main parts: hub and bearing assembly, spokes and rim. Each segment consists of media supported by spokes and tensioned in place by the rim. TC Series wheels are a fully segmented 4 spoke design.

TR and TF Series wheels feature a patented rim and spoke design, which allows for each section of the wheel to be tensioned independently. This simplifies field assembly and provides a flatter, rounder and stronger wheel.

Rim Connector:

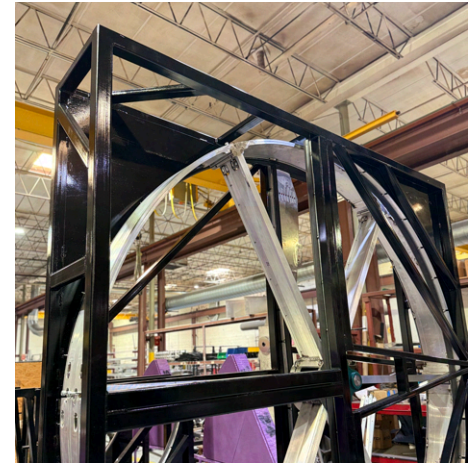
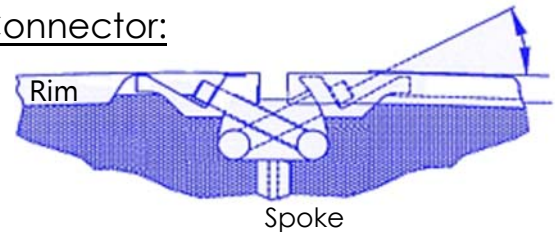

Spokes: **Spokes provide the structural integrity to limit deflection of the wheel and to eliminate mechanical fatigue of the media.**

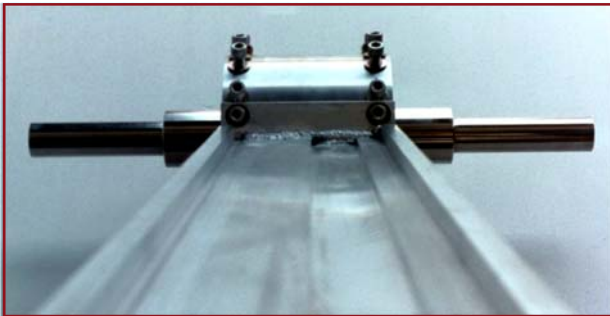

TR and TF Series spokes are extruded aluminum fashioned in the form of an "I" beam for added strength. TC series are aluminum custom extrusion fashioned in a grid box design. Each spoke has grooves which correspond to matching grooves machined into the media. This assures that each section of media is held securely in the exact position needed for a flat wheel.

Rims: **The rim holds each section of media in place and provides an area for the belts to ride.**

The rims are made from extruded aluminum and have "V" shaped grooves for the drive belts. This keeps the belts securely seated. The rims have ridges on the inside perimeter that fit into grooves machined in the media. This holds the media in proper position and provides a round and flat wheel.

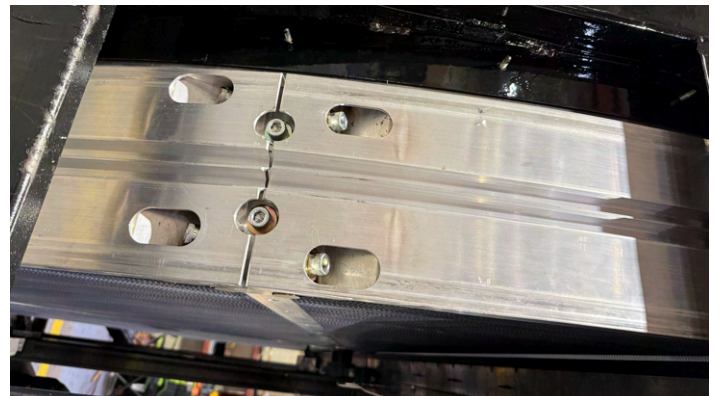

THERMOWHEEL® T Series

The Hub and Bearing Assembly:



Hub and bearings are the foundation on which the wheel is built. We use oversized bearings and machine each hub and shaft to the bearing manufacturer's tolerance. This provides the reliability needed for a minimum L-10 life of 1,000,000 hours.

The hub and bearing assembly support the wheel in the casing.

The Seals:

Seals must be strong, flexible and secure once in place. To achieve this, the seal is manufactured from an extruded aluminum strip mated to a labyrinth design extruded rubber seal that is secured directly to the wheel frame.

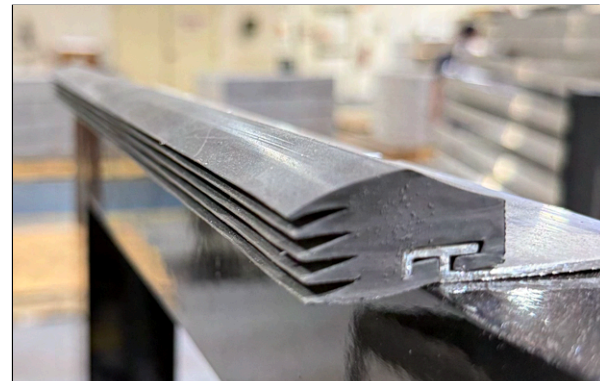

The seals can be set to 1/32" clearance from the media face, due to the fact that our "I" beam spokes feature almost zero deflection. This reduces leakage around the seals and provides for maximum performance and reliability.

The Motor Drive System:

The drive design is crucial to long term operation. A simple gravity tensioned twin "V" belt provides for outstanding performance and reliability. The belts ride in a groove on the rim to eliminate slippage and side to side belt movement. The drive is designed for a minimum life of 90,000 hours. A direct drive option is available with the speed reducer connected to an extended shaft via a keyway. All our motors feature variable or constant speed drive depending on the application. We use standard "V" belts, available at most supply stores, since this is the only part of a Thermowheel® that should ever need replacing.

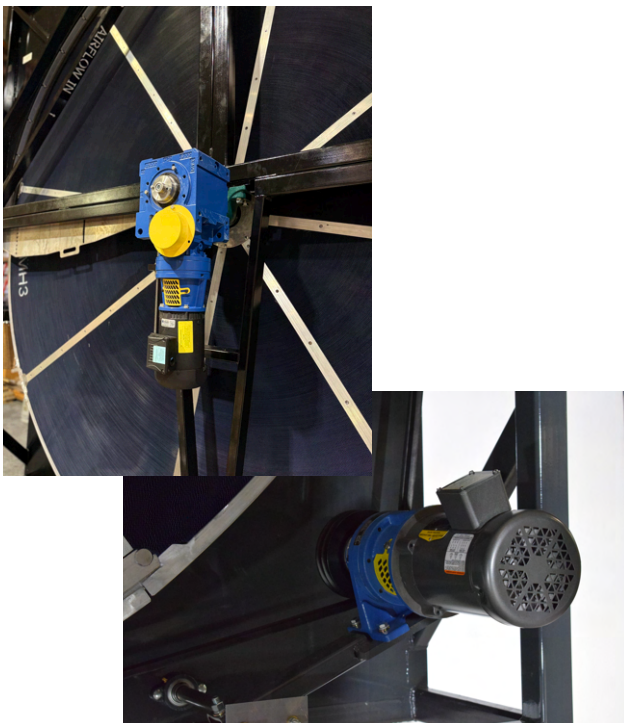



Control System:

The control system and sensors measure the temperature and/or humidity of the different air streams and control the wheel speed for maximum efficiency.

Our control system can be configured to provide the proper operation of the energy recovery wheel in all conditions and environments. We can custom configure the sensors so that the customer obtains the data and control required to ensure the highest operational efficiency. We can provide the interface to any existing HVAC control system.

The ETL Listed, UL 508A
Approved Control Panel is
Enclosed in A NEMA 4 Cabinet.



Media: The media provides for the transfer of heat and moisture between the airstreams.

Balanced Sieve 3 Å or Enthalpy Media, is the most efficient media available. It features a micro engineered desiccant, performance tested in accordance with ASHRAE Standard 84-91 and ARI Standards 1060-01, and features a standard 2 part epoxy edge coating for anti-corrosion, anti-mold and anti-bacterial protection. Sensible media, dehumidification media and media for high temperature and corrosive environments are also available.

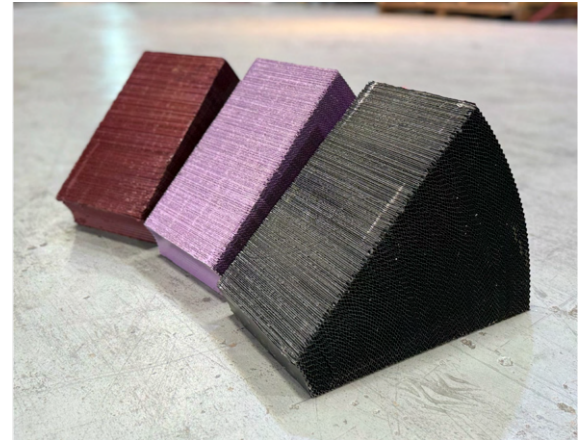

Installation:

For retrofit or field assembly applications, the unique design of the THERMOWHEEL® provides a flatter, stronger, more reliable wheel.



The field installation of TR and TF Series wheels can be performed by our trained technicians or by your staff with our supervision.

The casing, when required, is constructed of tubular steel or aluminum and is of a modular design built in either 2 or more sections to provide for easy assembly.



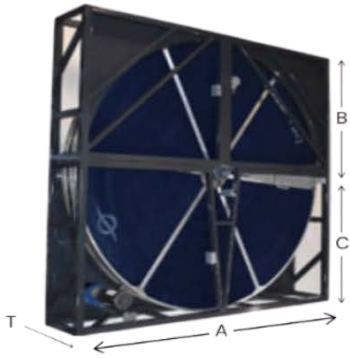

T SERIES DIMENSIONS

Model #	A (in.)	T (in.)	B (in.)	C (in.)	Motor HP	Weight Steel (lbs.)	Weight Aluminum (lbs.)
TF-1528	251	27	119	132	2	14,124	10,482
TF-1341	236	27	111 ½	124 ½	2	13,064	9,626
TF-1109	216	27	101 ½	114 ½	2	11,721	8,643
TF-920	198	23	94	104	2	8,038	6,340
TF-804	186	23	88	98	2	7,443	5,847
TF-723	174	21	82 ½	91 ½	1	5,167	4,544
TF-697	171	21	81	90	1	5,050	4,453
TF-671	168	21	79 ½	88 ½	1	4,884	4,305
TF-620	162	21	76 ½	85 ½	1	4,711	4,145
TF-572	156	21	73 ½	82 ½	1	4,495	3,939
TF-556	154	21	72 ½	81 ½	1	4,423	3,873
TF-526	150	21	70 ½	79 ½	1	4,281	3,745
TF-503	147	21	69	78	1	4,175	3,661
TF-474	143	21	67 ¾	75 ¾	¾	3,955	2,940
TF-460	141	21	66 ¾	74 ¾	¾	3,890	2,888
TF-432	137	21	64 ¾	72 ¾	¾	3,755	2,780
TF-418	135	21	63 ¾	71 ¾	¾	3,691	2,729
TF-398	132	21	62 ¾	69 ¾	¾	3,587	2,646
TF-385	130	21	61 ¾	68 ¾	¾	3,506	2,579
TF-359	126	21	59 ¾	66 ¾	¾	3,392	2,490
TF-347	124	21	58 ¾	65 ¾	¾	3,298	2,409
TF-329	120	20	57 ⅞	62 ⅞	½	2,782	2,185
TF-311	117	20	55 ⅞	61 ⅞	½	2,721	2,113
TF-294	114	20	54 ⅞	59 ⅞	½	2,649	2,043
TF-282	112	20	53 ⅞	58 ⅞	½	2,580	1,995
TF-261	108	20	51 ⅞	56 ⅞	½	2,469	1,905
TF-245	105	20	49 ⅞	55 ⅞	½	2,388	1,837
TF-225	101	20	47 ⅞	53 ⅞	½	2,284	1,751
TF-215	99	20	46 ⅞	52 ⅞	½	2,209	1,685
TF-200	96	20	45 ⅞	50 ⅞	½	2,154	1,644
TF-191	94	20	44 ⅞	49 ⅞	½	2,103	1,603
TF-182	92	20	43 ⅞	48 ⅞	½	2,052	1,561

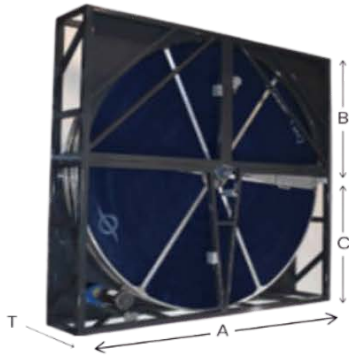

T SERIES DIMENSIONS

Model #	A (in.)	T (in.)	B (in.)	C (in.)	Motor HP	Weight Steel (lbs.)	Weight Aluminum (lbs.)
TF-173	89 1/2	19	42 3/8	47 1/8	1/3	1,385	1,103
TF-167	88	19	41 5/8	46 3/8	1/3	1,357	1,079
TF-166	87 1/2	19	41 3/8	46 1/8	1/3	1,347	1,071
TF-152	84 1/2	19	39 7/8	44 5/8	1/3	1,291	1,025
TF-150	84	19	39 5/8	44 3/8	1/3	1,282	1,016
TF-144	82 1/2	19	38 7/8	43 5/8	1/3	1,253	992
TF-136	80 1/2	19	37 7/8	42 5/8	1/3	1,219	964
TF-134	80	19	37 5/8	42 3/8	1/3	1,208	954
TF-128	78 1/2	19	36 7/8	41 5/8	1/3	1,180	931
TF-121	76 1/2	19	35 7/8	40 5/8	1/3	1,149	905
TF-119	76	19	35 5/8	40 3/8	1/3	1,137	896
TF-114	74 1/2	19	34 7/8	39 5/8	1/3	1,112	874
TF-107	72 1/2	19	33 7/8	38 5/8	1/3	1,078	846
TF-105	72	19	33 5/8	38 3/8	1/3	1,070	839
TF-96	69 1/2	19	32 3/8	37 1/8	1/3	1,030	804
TF-92	68	19	31 5/8	36 3/8	1/3	1,008	788
TF-87	66 1/2	19	30 7/8	35 5/8	1/3	979	761
TF-81	64 1/2	19	29 7/8	34 5/8	1/3	949	737
TF-79	64	19	29 5/8	34 3/8	1/3	942	731

Model #	A (in.)	T (in.)	B (in.)	C (in.)	Motor HP	Weight Aluminum (lbs.)
TC-82	60	18	28.5	31.5	1/4	385
TC-71	56	18	26.5	29.5	1/4	350
TC-60	52	18	24.5	27.5	1/4	315
TC-50	48	18	22.5	25.5	1/4	283
TC-41	44	18	20.5	23.5	1/4	251
TC-33	40	18	18.5	21.5	1/4	217
TC-22	34	18	15.5	18.5	1/4	178
TC-14	28	18	12.5	15.5	1/4	144

Problems solved by Thermowheel®

Most wheels don't fail because the media isn't doing its job. They fail because of structural design faults.

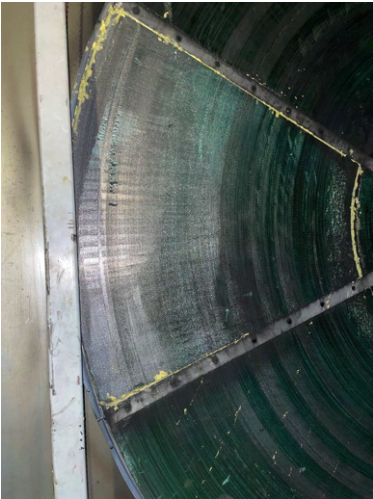

Common failures like these pictured here are caused by flawed designs. The T Series THERMOWHEEL® solves all of these problems and more

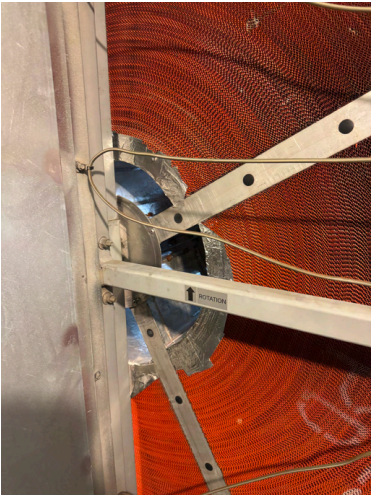

Engineering Reliability And Performance



Casing Frame Structure:

The structural casing can be provided in one, two or more sections. When assembled it shall allow for a maximum 1/32" rotor deflection during maximum rated airflow conditions.

Purge Section:

A purge section shall be provided to eliminate transfer of exhaust air into the supply air, and shall be field adjustable to provide the desired purge air volume.

Hub and Bearings:

External bearings shall be sized to provide a minimum L-10 life of 1,000,000 hours of operation, and shall be changeable without a complete disassembly of the rotor. Shaft shall be machined as to provide a shoulder against the bearings for a positive locked position to eliminate any lateral movement of the rotor due to set screw failure or shaft wear.

Spokes:

The spokes shall be made of extruded aluminum with an "I" beam shape to limit deflection of the rotor to 1/32" for the maximum rated airflow. Spokes shall consist of a primary and a secondary spoke to allow for easy field assembly. Surfaces to be serrated for increased friction and air turbulence across the seals.

Rims:

Rims shall be made of 2 extruded aluminum sections. 1 inner rim and 1 outer rim with grooves for the twin "V" belts, and guide flanges for securing the media. The 2 sections shall be welded together to form a tubular structure for improved strength in order to maintain an accurate radius and rotor roundness during the installation process.

Rim Joint:

The rim joint shall connect the spoke ends and the rim ends together in such a way that the heat transfer media can be installed under field conditions without any media deformation or misfits causing future problems. The rim joints shall provide a gradual compression of each section by independently applying increased tension of the rim bolts without the use of any special tools or devices.

Rotor Media:

The rotor media must be provided in segments. Each media segment must be machined to fit in between a primary and secondary spoke and a guiding flange of the outside rim. Each segment of media must be compressed independently of all other segments during the assembly process without causing any angular deformation and resulting misfits between the spokes and media parts, and to provide a wheel with a flatness of +/- 1/32". No adhesives or silicone shall be necessary to secure the media in place in order to allow for future replacement in the event of damage to a section. The rotor system must be able to accommodate all acceptable media types for applications requiring equal sensible and latent recovery.

Seals:

The seals shall be of a maintenance free "non-contact" type to eliminate wear and excessive drag, while still being capable of resisting high pressure differences up to 12 in.wc. without deflection causing leaks.

Drive System:

The drive must be gravity tensioned and shall use 2 standard "B" section V- belts to drive the rotor. The speed reducer must be grease lubricated, maintenance free with a flexible Love-Joy input coupling or a Direct Drive Motor and Speed reducer shall be attached to the extended shaft via a key-way.

Speed Control:

The speed control system shall be a variable frequency inverter operating a standard inverter rated AC motor, capable of operating the rotor from 1/4 rpm to 20 rpm or to whatever is required for the type of media used. It shall integrate with the control system.

Temperature or Enthalpy Controller:

The Wheel Controls shall monitor the temperature or Enthalpy conditions of the Airflow streams and adjust the wheel speed to maintain the programmed setpoints. Adjustable set points shall be for the supply air temperature, cool/heat mode enable conditions, sleep mode, and frost control.

Maintenance:

The entire rotor and wheel assembly shall require only limited maintenance of biannual greasing of the main bearings and inspection of the drive system.

Warranty:

A standard 10 or 3 year material and labor warranty covering all materials supplied and installed by Thermotech.

* U.S. patent # 6,422,299 Canadian patent # 2,373,417

** The entire specifications for TR, TF and TC SeriesThermowheel® are available at: thermotech-usa.com

*** TC Series wheels feature a 1 piece frame and single rim. Fixed rim connector with a grid box spoke design. Adhesives are used and entire rotor can be removed via side access.

info@thermotech-usa.com

Tel (813) 865-4701

www.thermotech-usa.com